

## SAWING WIDE BOARD

### PARALLEL SLIDING HOLDER

To cut wide board.

Parallel sliding holder is designed to be attached to the Guide base to cut wide board.

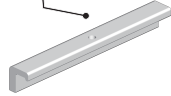

### ① SCREW-B

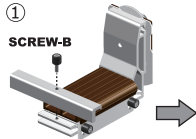

Attach the Parallel sliding holder to the Guide base with Screw-B.

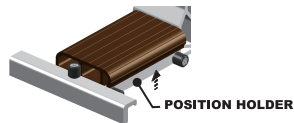

The Position holder needs to be stowed into the Guide grip.

### ② SLIDE BAR

(A straight bar is needed to slide the Guide against.)

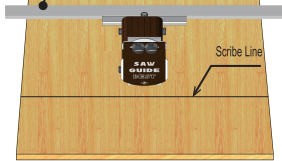

Firstly make a straight scribe line on the board, and place the Guide against the Slide bar.

### ③ CLAMP

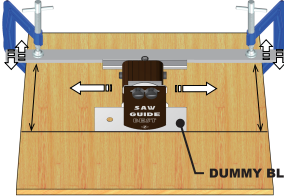

Insert Dummy blade into the space between Guide base and Guide plates, and adjust the position of the Guide and Slide bar. Make sure the Dummy blade accurately sits against the scribe line. Then, clamp the slide bar firmly.

### ④

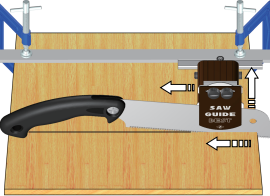

Replace the Dummy blade with the saw, then start sawing by moving the guide backward. Ensure that the Parallel sliding holder remains firmly against the slide bar.

### ※ Sawing Tip

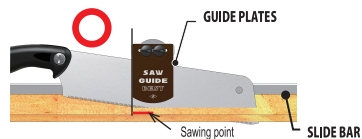

Sawing point (teeth loading point against wood) needs to be remained right under the center of the Guide plate to avoid chattering amid strokes, and to saw accurately.

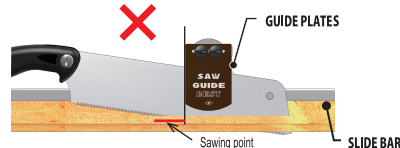

## FOR LEFT-HANDED USERS

For Left-handed users, the Position holder and Guide grip can be attached to the other side of the Guide base as shown below.

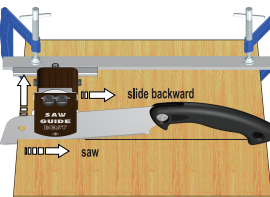
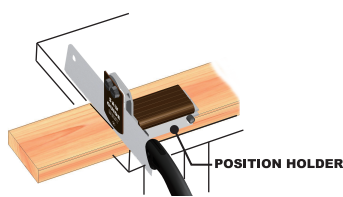
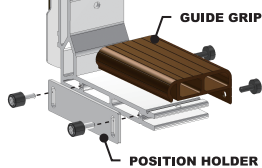

# SAW GUIDE BEST

WOODWORKING AUXILIARY TOOL

## INSTRUCTION SHEET

## GUIDE KIT

### DUMMY BLADE (thickness:0.6mm)

To adjust Guide position against a scribe line.

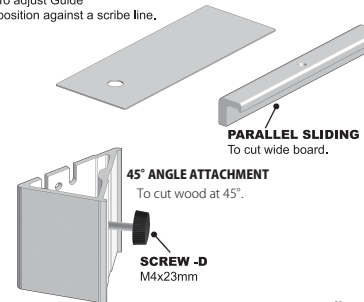

PARALLEL SLIDING HOLDER  
To cut wide board.

45° ANGLE ATTACHMENT  
To cut wood at 45°.

SCREW -D  
M4x23mm

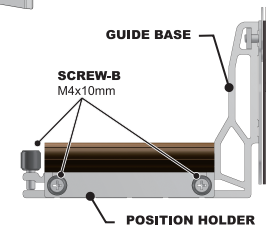

SCREW-B  
M4x10mm

GUIDE BASE  
POSITION HOLDER

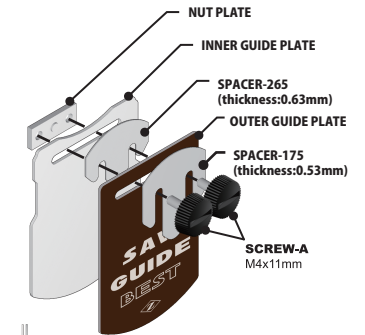

NUT PLATE

INNER GUIDE PLATE

SPACER-265  
(thickness:0.63mm)

OUTER GUIDE PLATE

SPACER-175  
(thickness:0.53mm)

SCREW-A  
M4x11mm

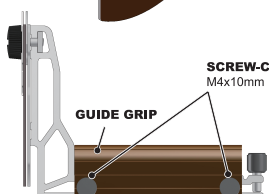

SCREW-C  
M4x10mm

GUIDE GRIP

### UNIVERSAL S-265 (SAW BLADE)



APPLICATION: Ideal for aggressive cross/rip/slant cut in solid wood, plywood etc.  
SPEC: Blade thickness:0.6mm /Pitch:1.75mm /Kerf:0.92mm /Blade length:265mm

### UNIVERSAL S-175 (SAW BLADE)



APPLICATION: Ideal for fine cross/rip/slant cut in solid wood, plywood etc.  
SPEC: Blade thickness:0.5mm /Pitch:1.4mm /Kerf:0.66mm / Blade length:180mm



SCREW

GRIP

- Saw blades are replaceable.
- The saw grip is compatible to the packed two blades.
- ※ Saw blade must be firmly attached to the grip for safe and efficient use.



### CAUTION

Do not drop the guide or the saw as damage to them may occur.

Do not over tighten screws, as this may cause damage to screws, nuts or the guide.

Saw Guide Best cannot be used with double-edged saws or saws which have blades thicker than 0.5 or 0.6mm.

Always use your Saw Guide Best with ZETSAW Universal S-265 or Universal S-175.

Do not use Saw Guide Best for any purpose for which it was not intended.

### Notice:

Specifications may change without notice to improve quality.

All rights reserved by Z Hanbai Co.,Ltd.



# Z Hanbai Co.,Ltd.

Post code: 673-0404

Address: 561 Omura Miki-city Hyogo pref. Japan

TEL : 0081-(0)794-83-2001 FAX:0081-(0)794-83-5111

URL : [www.z-saw.co.jp/en](http://www.z-saw.co.jp/en)

EMAIL : [sales1@z-saw.co.jp](mailto:sales1@z-saw.co.jp)

## BLADE REPLACEMENT

**CAUTION :** Be sure to always wear gloves or wrap the blade with a cloth while replacing saw blade.

### Blade attachment



Insert the blade into the handle until the slit in the blade is completely covered, then screw to fix the blade firmly.

### Blade detachment

Using a coin or screw driver to loosen the screw, and then pull the blade out of the grip.

※ The screw is not necessarily removed from the grip.

## SAW GUIDE KIT & TIPS

### SAW & SPACER

Spacer-265 (Shorter one), which is designed to be used with Universal S-265 is inserted at factory prior to shipment, and in case of fine cut, the Spacer-175 (longer one) can be easily replaced to be used with saw of Universal S-175.

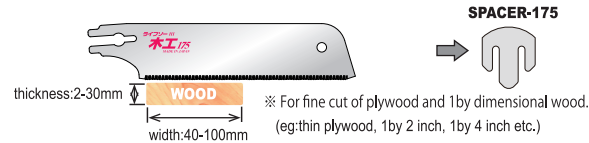

### HOW TO REPLACE SPACER

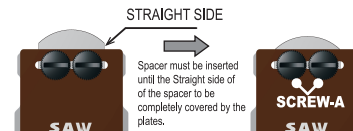
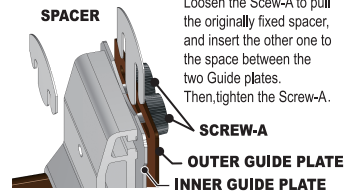

### GUIDE ANGLE & HOLDING

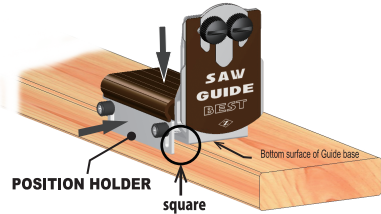

Hold the guide squarely against the wood so to make the mounting angle between wood and guide to 90°.

### POSITION HOLDER ADJUSTMENT

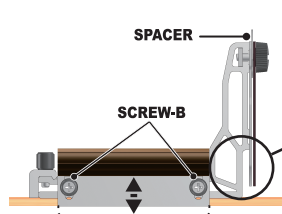

Depth of Position holder can be adjusted according to the thickness of the wood by loosening Screw-B.

### FUNCTION OF GUIDE PLATES

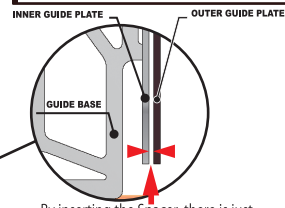

By inserting the Spacer, there is just right space for guiding the saw to cut the wood squarely.

※ In case extra friction occurs when inserting the blade, the Spacer may not be correctly inserted between the Guide plates.

### POSITION OF GUIDE PLATES

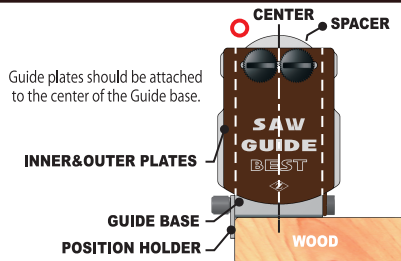

Guide plates should be attached to the center of the Guide base.

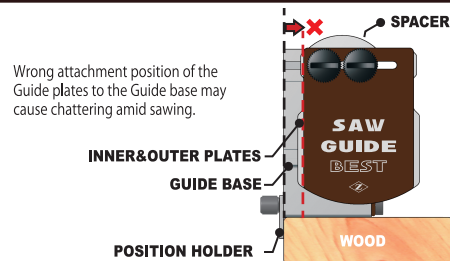

Wrong attachment position of the Guide plates to the Guide base may cause chattering amid sawing.

## 90 DEGREE SQUARE CUT

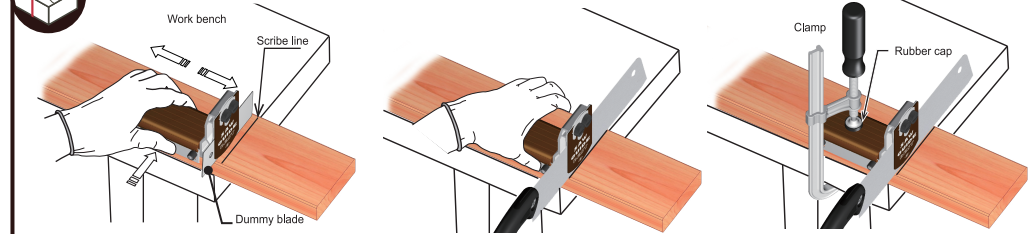

• Scribe a cutting line on the wood.

• Insert the Dummy blade into the Guide to adjust the position of Guide.

• Hold the Guide and wood together firmly.

• Pull the Dummy blade out, and insert the saw into the space between the Guide plates.

• Clamping the Guide and wood can make the strokes much stable so to make the cut more accurate.

※ A clamp with rubber cap may enhance the stability amid cut.

※ Never Clamp too tight, too much load on the Guide grip may damage the guide.

SAWING TIP: Sawing with the weight of the saw, and make the strokes with full length of the blade may largely enhance sawing efficiency.

## 45 DEGREE MITER CUT

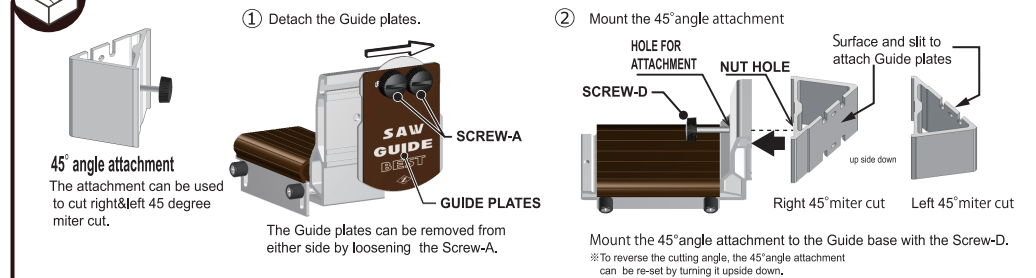

③ Attach the Guide plates

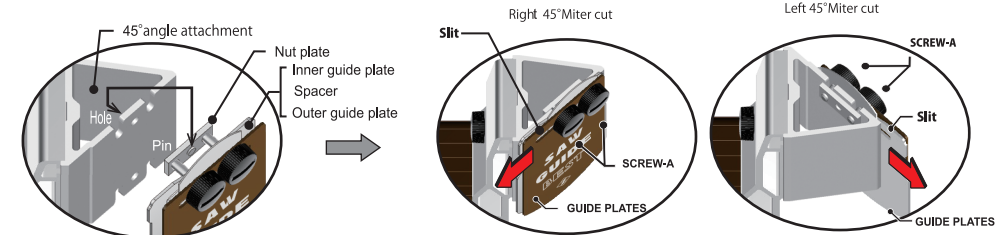

Mount the Nut plate behind the Guide base, and locate the protruding pin on the Nut plate into the hole in 45° angle attachment.

Pull the Guide plates inward (to the arrow direction) to the end of Slit on the Guide plates as shown above, and tighten the Screw-A so to enhance the stability of sawing strokes.

※ Never push the plates outward to attach the Guide plates, which may cause unstable sawing, and lead to the inaccurate cutting result.

